



2013 – PH

Test Paper Code : PH

Time : 3 Hours Maximum Marks : 100

**INSTRUCTIONS**

1. This question-cum-answer booklet has 32 pages and has 30 questions. Please ensure that the copy of the question-cum-answer booklet you have received contains all the questions.
2. Write your **Registration Number, Name and the name of the Test Centre** in the appropriate space provided on the right side.
3. Write the answers to the objective questions against each Question No. in the **Answer Table for Objective Questions**, provided on Page No. 4. Do not write anything else on this page.
4. Each objective question has 4 choices for its answer: (A), (B), (C) and (D). Only **ONE** of them is the correct answer. There will be **negative marking** for wrong answers to objective questions. The following marking scheme for objective questions shall be used :
  - (a) For each correct answer, you will be awarded **2 (Two)** marks.
  - (b) For each wrong answer, you will be awarded **-0.5 (Negative 0.5)** mark.
  - (c) Multiple answers to a question will be treated as a wrong answer.
  - (d) For each un-attempted question, you will be awarded **0 (Zero)** mark.
  - (e) Negative marks for objective part will be carried over to total marks.
5. Answer the fill in the blank type and descriptive type questions only in the space provided after each question. No negative marks for fill in the blank type questions.
6. Do not write more than one answer for the same question. In case you attempt a fill in the blank or a descriptive question more than once, please cancel the answer(s) you consider wrong. Otherwise, the answer appearing last only will be evaluated.
7. All answers must be written in blue/black/blue-black ink only. Sketch pen, pencil or ink of any other colour should not be used.
8. All rough work should be done in the space provided and scored out finally.
9. No supplementary sheets will be provided to the candidates.
10. **Clip board, log tables, slide rule, cellular phone and electronic gadgets in any form are NOT allowed. Non Programmable Calculator is allowed.**
11. The question-cum-answer booklet must be returned in its entirety to the Invigilator before leaving the examination hall. Do not remove any page from this booklet.
12. Refer to special instructions/useful data on the reverse.



2013 – PH

**READ INSTRUCTIONS ON THE LEFT SIDE OF THIS PAGE CAREFULLY**

REGISTRATION NUMBER						
Name :						
Test Centre :						

**Do not write your Registration Number or Name anywhere else in this question-cum-answer booklet.**

I have read all the instructions and shall abide by them.

.....

Signature of the Candidate

I have verified the information filled by the candidate above.

.....

Signature of the Invigilator

**Special Instructions/ Useful Data**

Planck's constant ( $h$ )	=	$6.63 \times 10^{-34}$ J.s
	=	$4.14 \times 10^{-15}$ eV.s
Mass of electron ( $m_e$ )	=	$9.10 \times 10^{-31}$ kg
Speed of light in vacuum ( $c$ )	=	$3 \times 10^8$ ms <sup>-1</sup>

**IMPORTANT NOTE FOR CANDIDATES**

- Questions 1-10 (objective questions) carry *two* marks each, questions 11-20 (fill in the blank questions) carry *three* marks each and questions 21-30 (descriptive questions) carry *five* marks each.
- The marking scheme for the objective type question, is as follows:
  - (a) For each correct answer, you will be awarded **2 (Two)** marks.
  - (b) For each wrong answer, you will be awarded **-0.5 (Negative 0.5)** mark.
  - (c) Multiple answers to a question will be treated as a wrong answer.
  - (d) For each un-attempted question, you will be awarded **0 (Zero)** mark.
  - (e) Negative marks for objective part will be carried over to total marks.
- There is no negative marking for fill in the blank questions.
- Write the answers to the objective questions in the Answer Table for Objective Questions provided on page 4 only.

**Objective Questions**

Q.1 The inverse of the matrix

$$M = \begin{pmatrix} 0 & 1 & 1 \\ 0 & 0 & 1 \\ 1 & 0 & 0 \end{pmatrix} \text{ is}$$

- (A)  $M - I$                       (B)  $M^2 - I$                       (C)  $I - M^2$                       (D)  $I - M$   
 where I is the identity matrix.

Q.2 The value of  $\sqrt{i} + \sqrt{-i}$ , where  $i = \sqrt{-1}$ , is

- (A) 0                      (B)  $\frac{1}{\sqrt{2}}$                       (C)  $\sqrt{2}$                       (D)  $-\sqrt{2}$

Q.3 A particle is released at  $x = 1$  in a force field  $\vec{F}(x) = \left( \frac{2}{x^2} - \frac{x^2}{2} \right) \hat{e}_x$ ,  $x \geq 0$ . Which one of the following statements is FALSE?

- (A)  $\vec{F}(x)$  is conservative  
 (B) The angular momentum of the particle about the origin is constant  
 (C) The particle moves towards  $x = \sqrt{2}$   
 (D) The particle moves towards the origin

- Q.4 A traveling pulse is given by  $f(x,t) = A \exp\left(\frac{2abxt - a^2x^2 - b^2t^2}{c^2}\right)$ , where  $A$ ,  $a$ ,  $b$ , and  $c$  are positive constants of appropriate dimensions. The speed of the pulse is
- (A)  $\frac{b}{a}$                       (B)  $\frac{2b}{a}$                       (C)  $\frac{cb}{a}$                       (D)  $\frac{b}{2a}$
- Q.5 If the dimensions of mass, length, time and charge are  $M$ ,  $L$ ,  $T$  and  $C$  respectively, the dimensions of the magnetic induction field  $\vec{B}$  is
- (A)  $ML^2T^{-1}C^{-1}$       (B)  $MT^{-1}C^{-1}$               (C)  $L^2T^{-1}C$               (D)  $L^{-1}T^{-1}C$
- Q.6 A blackbody at temperature  $T$  emits radiation at a peak wavelength  $\lambda$ . If the temperature of the blackbody becomes  $4T$ , the new peak wavelength is
- (A)  $\frac{1}{256}\lambda$                   (B)  $\frac{1}{64}\lambda$                       (C)  $\frac{1}{16}\lambda$                       (D)  $\frac{1}{4}\lambda$
- Q.7 Let  $N_{MB}$ ,  $N_{BE}$ ,  $N_{FD}$  denote the number of ways in which two particles can be distributed in two energy states according to Maxwell-Boltzmann, Bose-Einstein and Fermi-Dirac statistics respectively. Then  $N_{MB} : N_{BE} : N_{FD}$  is
- (A) 4:3:1                      (B) 4:2:3                      (C) 4:3:3                      (D) 4:3:2
- Q.8 Electric field component of an electromagnetic radiation varies with time as  $E = a(\cos \omega_0 t + \sin \omega t \cos \omega_0 t)$ , where  $a$  is a constant and the values of  $\omega$  and  $\omega_0$  are  $1 \times 10^{15} \text{ s}^{-1}$  and  $5 \times 10^{15} \text{ s}^{-1}$ , respectively. This radiation falls on a metal of work function 2 eV. The maximum kinetic energy (in eV) of photoelectrons is
- (A) 0.64                      (B) 1.30                      (C) 1.70                      (D) 1.95
- Q.9 The fraction of volume unoccupied in the unit cell of the body centered cubic lattice is
- (A)  $\frac{8 - \sqrt{3}\pi}{8}$                   (B)  $\frac{\sqrt{3}\pi}{8}$                       (C)  $\frac{6 - \sqrt{2}\pi}{6}$                   (D)  $\frac{\pi}{3\sqrt{2}}$

Q.10 For an ideal op-amp circuit given below, the dc gain and the cut off frequency, respectively are

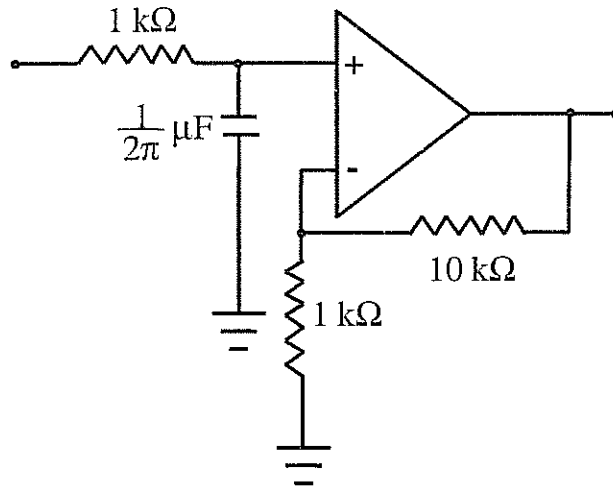

- (A) 1 and 1 kHz
- (C) 11 and 1 kHz

- (B) 1 and 100 Hz
- (D) 11 and 100 Hz

***Answer Table for Objective Questions***

Write the Code of your chosen answer only in the 'Answer' column against each Question Number. Do not write anything else on this page.

Question Number	Answer	Do not write in this column
01		
02		
03		
04		
05		
06		
07		
08		
09		
10		

**FOR EVALUATION ONLY**

Number of Correct Answers		Marks	(+)
Number of Incorrect Answers		Marks	(-)
Total Marks in Question Nos. 1-10			( )

## Fill in the blank questions

Q.11 The solution of the differential equation  $dz(x, y) + xz(x, y)dx + yz(x, y)dy = 0$  is

Ans:

Q.12 Given that  $f(1) = 1$ ,  $f'(1) = 1$  and  $f''(1) = 1$ , the value of  $f(\frac{1}{2})$  is

Ans:

- Q.13 Two tubes A and B are connected through another tube C. A mercury manometer is connected between B and C (see figure). The diameters of B and C are 0.04 m and 0.01 m, respectively. An incompressible fluid of density  $1.0 \times 10^3 \text{ kgm}^{-3}$  enters A, and leaves B with a constant speed  $0.2 \text{ ms}^{-1}$ . If the density of mercury is  $13.6 \times 10^3 \text{ kgm}^{-3}$ , the height  $h$  of the mercury column in the manometer is  
(Take acceleration due to gravity  $g = 10 \text{ ms}^{-2}$ )

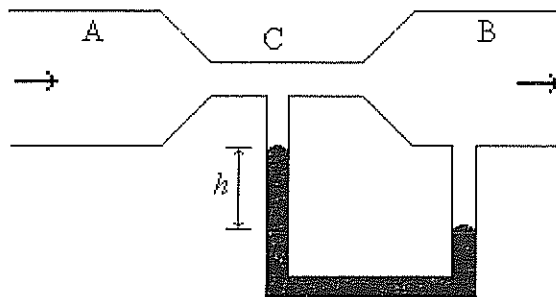

Ans:

- Q.14 The path of a particle of mass  $m$ , moving under the influence of a central force, in plane polar coordinates is given by  $r = r_0 e^{k\theta}$ , where  $r_0$  and  $k$  are positive constants of appropriate dimensions. The angular momentum of the particle is  $L$  and its total energy is zero. The potential energy function  $V(r)$ , in terms of  $m$ ,  $L$  and  $k$  is

Ans:



- Q.15 The dimensions of a thin convex lens of refractive index  $n$  are shown in the figure. The radius of curvature of the lens in terms of  $n$ ,  $h$  and  $\delta$  (where,  $\delta \ll h$ ) is

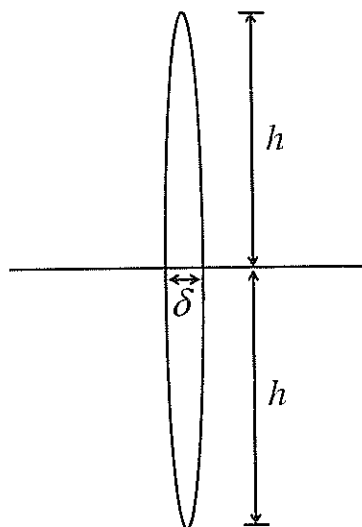

Ans:

- Q.16 A charged particle of mass  $m$ , charge  $q$  and constant velocity  $\vec{v}$  enters a uniform magnetic field  $\vec{B} = B_0 \hat{e}_x$ , ( $B_0 > 0$ ), at an angle  $\theta$  to the direction of magnetic field. Find the angle  $\theta$ , if in one revolution of the helical motion, the particle advances along the direction of the magnetic field a distance equal to the radius of the helical path.

Ans:

- Q.17 Two thermally isolated identical systems have heat capacities which vary as  $C_V = \beta T^3$  (where  $\beta > 0$ ). Initially one system is at 300 K and the other at 400 K. The systems are then brought into thermal contact and the combined system is allowed to reach thermal equilibrium. The final temperature of the combined system is

Ans:

- Q.18 A beam of X-rays of wavelength 0.2 nm is incident on a free electron and gets scattered in a direction with respect to the direction of the incident radiation resulting in maximum wavelength shift. The percentage energy loss of the incident radiation is

Ans:

Q.19 A free particle of mass  $m$  is confined to a region of length  $L$ . The de Broglie wave associated with the particle is sinusoidal in nature as given in the figure. The energy of the particle is

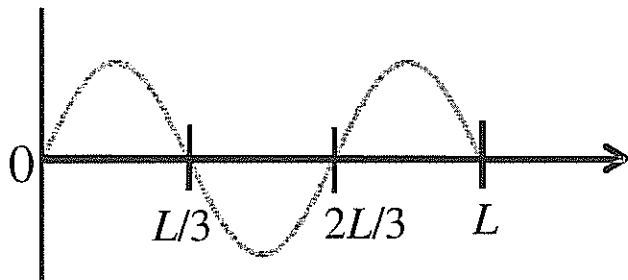

Ans:

Q.20 A variable power supply ( $5\text{ V} - 20\text{ V}$ ) is connected to a Zener diode specified by a breakdown voltage of  $10\text{ V}$  (see figure). The ratio of the maximum power to the minimum power dissipated across the load resistor is

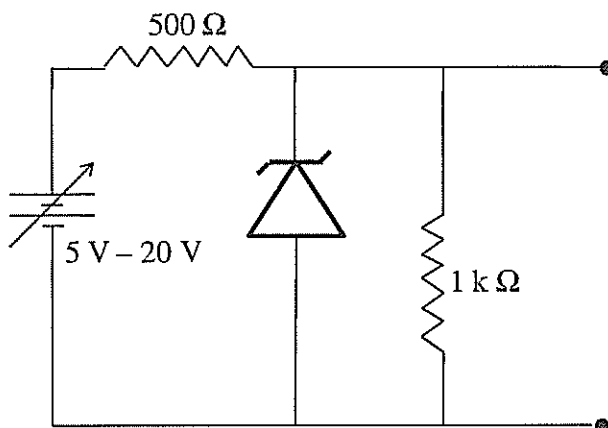

Ans:

**Descriptive questions**

- Q.21 Apply Gauss divergence theorem to the gravitational field due to a spherical object of mass  $M$  and uniform density  $\rho$  located at the origin. Obtain Gauss's law for gravitation (analogous to the Gauss law in electrostatics) in integral and differential forms.

Space for the answer

A

Space for the answer

A large, empty rectangular box with a dashed border, occupying most of the page. It is intended for the student to write their answer to the question.

A

- Q.22 A thin annular disc of inner and outer radii  $a$  and  $b$  ( $a < b$ ) respectively has uniform mass density  $\sigma_s$  and is placed in the  $xoy$ -plane such that its axis lies along the  $z$ -axis. Determine the gravitational force due to the disc on a particle of mass  $m$  located on the  $z$ -axis at a distance  $z$  from the origin. If the particle is released at  $z$ , such that  $z \ll a, b$ , describe the nature of motion of the particle.

Space for the answer

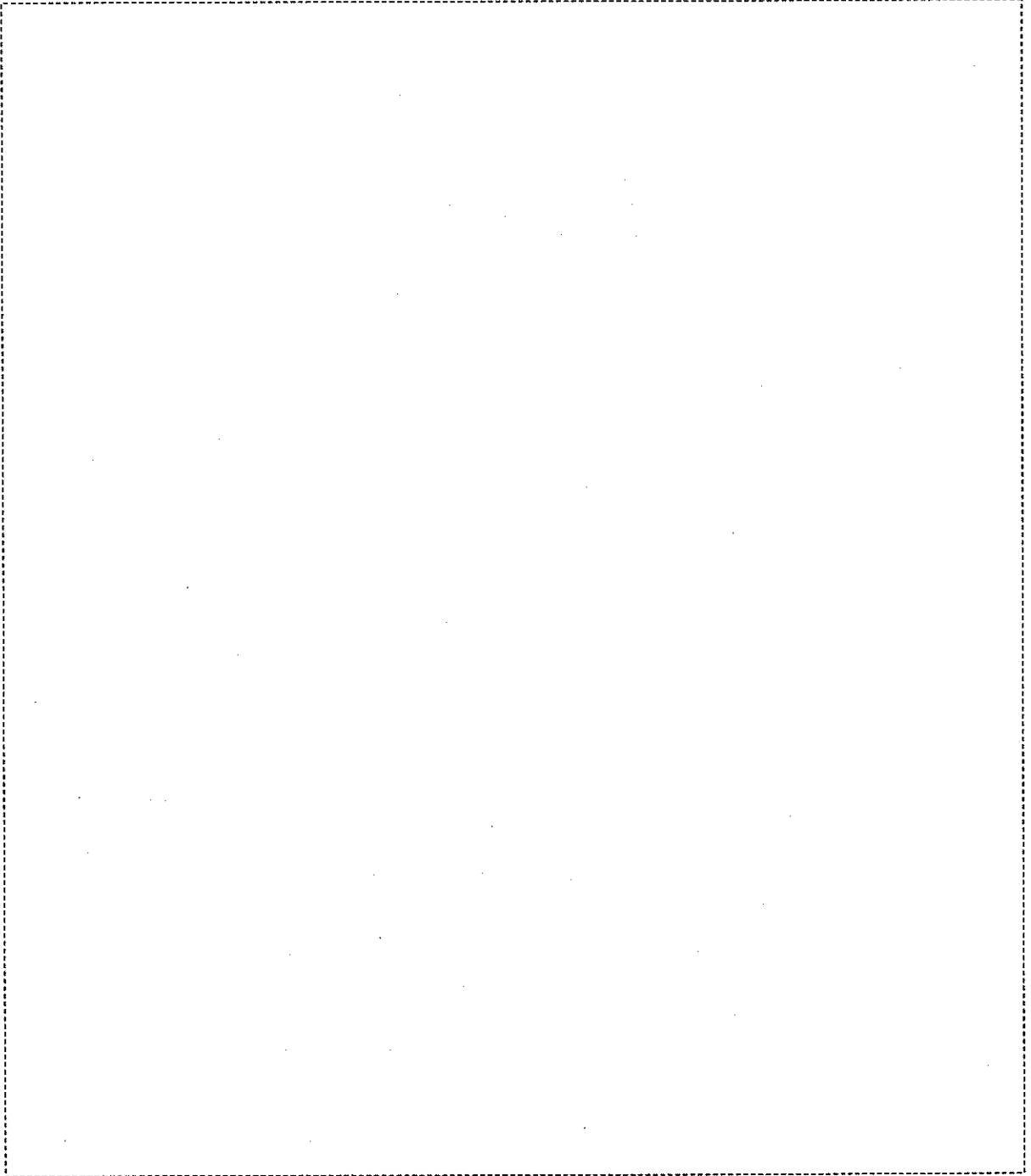

A

Space for the answer

A large, empty rectangular box with a dashed border, occupying most of the page. It is intended for the student to write their answer to the question.

- Q.23 A concentric spherical volume of inner radius  $a$  and outer radius  $b$  is filled with a material of finite conductivity specified by

$$\sigma(r) = \frac{A}{r^2},$$

where  $A$  is a positive constant of appropriate dimensions. The outer surface is grounded and the inner surface is maintained at a potential  $V_0$ . Calculate the resistance of this configuration.

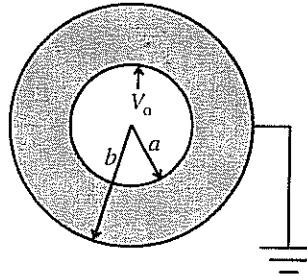

Space for the answer



Q.24 A conducting solid sphere of radius  $a$ , carrying a charge  $q$  is kept in a dielectric of dielectric constant  $k$ , such that half the sphere is surrounded by the dielectric as shown in figure. Find the surface charge densities in the upper and lower hemispherical surfaces.

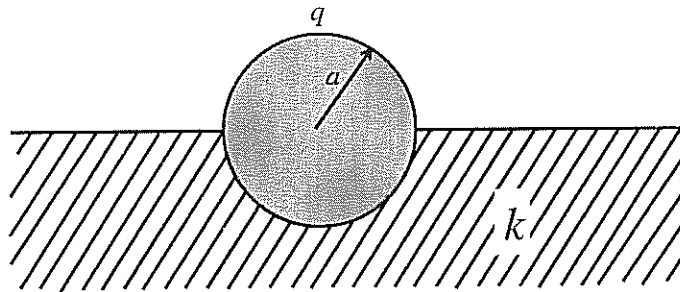

Space for the answer

A large rectangular area enclosed by a dashed line, intended for the student to write their answer to the problem.

A

- Q.25 A particle of mass  $m$  is subjected to a potential  $V(x) = ax^2$ ,  $-\infty < x < \infty$ , where  $a$  is a positive constant of appropriate dimensions. Using the relation  $\Delta x \Delta p \approx \frac{\hbar}{2}$ , estimate the minimum energy of the particle.

Space for the answer

- Q.26 A hollow cylinder (closed at both ends) with adiabatic walls is divided into  $n$  equal cells ( $C_1, C_2, \dots, C_n$ ) using discs  $D_1, D_2, \dots, D_{n-1}$  (see figure). The discs can slide freely without friction. The first disc ( $D_1$ ) is adiabatic and the remaining discs are diathermal (thermally conducting). Each cell contains one mole of ideal monoatomic gas. Let the initial pressure, volume and temperature of each cell be  $P_0, V_0$  and  $T_0$ , respectively. The gas in cell  $C_1$  (first cell) is heated slowly until the temperature of the gas in cell  $C_n$  (last cell) reaches final equilibrium temperature  $4T_0$ . Find the volume of the first cell in terms of the number of cells ( $n$ ) and the initial volume ( $V_0$ ).

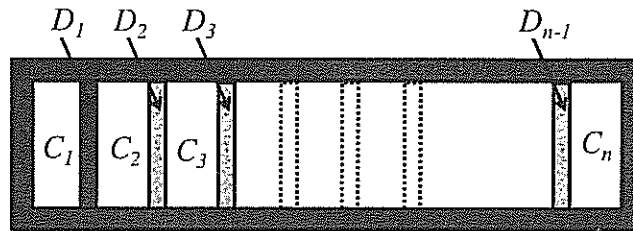

Space for the answer

A

Space for the answer

A large rectangular area defined by a dashed black border, intended for the student to write their answer to the question.

- Q.27 A spaceship  $S_1$  leaves the Earth along the positive  $x$ -direction. Another spaceship  $S_2$  also leaves the Earth along the direction which makes an angle  $60^\circ$  with  $x$ -axis. The speeds of  $S_1$  and  $S_2$  are measured as  $0.6c$  and  $0.9c$  respectively by an observer on the Earth. Find the speed of  $S_2$  as measured by an observer in  $S_1$ .

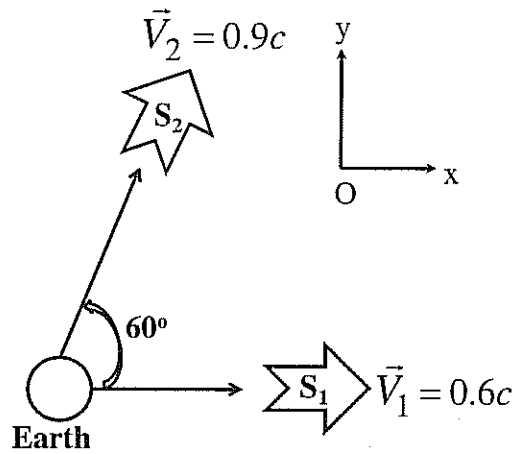

Space for the answer

A

Space for the answer

A large rectangular area defined by a dashed black border, occupying most of the page. It is intended for the student to write their answer to the question.

Q.28 For the given circuit, calculate the input impedance, output impedance and voltage gain.  
 Use  $\beta = 200$ ,  $V_{BE} = 0.7 \text{ V}$  and  $r_e = \frac{26 \text{ mV}}{I_E}$ .

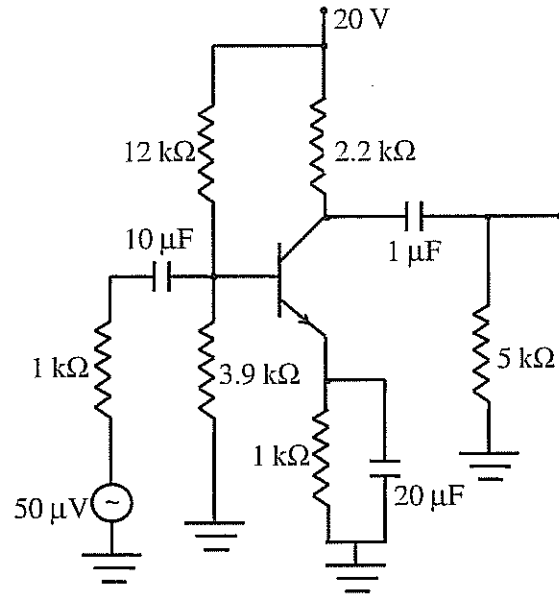

Space for the answer

A

Space for the answer

A large, empty rectangular box with a dashed border, intended for the student to write their answer to the question.





Q.29 The mass density of a disc of mass  $m$  and radius  $R$  varies as

$$\rho(r) = \rho_0 \left(1 - \frac{r}{R}\right) \text{ for } 0 \leq r \leq R$$
$$= 0 \quad \text{for } r > R.$$

Find the moment of inertia of the disc about the axis perpendicular to the plane of the disc and passing through the centre of the disc in terms of  $m$  and  $R$ .

Space for the answer

A

- Q.30 The speed of sound propagation in air as a function of temperature  $T$  is given by  $v = \alpha T$ , where  $\alpha$  is a constant of appropriate dimensions. Calculate the time taken for a sound wave to travel a distance  $L$  between two points  $A$  and  $B$ , if the air temperature between the points varies linearly from  $T_1$  to  $T_2$ .

Space for the answer



Space for rough work



**Space for rough work**



**Space for rough work**

A

Space for rough work



**Space for rough work**



Space for rough work





Space for rough work

A

**Space for rough work**

<b>2013 - PH</b>	
<b>Objective Part</b>	
<b>(Question Number 1 – 10)</b>	
<b>Total Marks</b>	<b>Signature</b>

<b>Fill in the blanks Part and Descriptive Part</b>					
<b>Question Number</b>	<b>Marks</b>		<b>Question Number</b>	<b>Marks</b>	
11			21		
12			22		
13			23		
14			24		
15			25		
16			26		
17			27		
18			28		
19			29		
20			30		
<b>Total Marks in Fill in the Blanks Part and Descriptive Part</b>					

<b>Total (Objective Part)</b>	:	
<b>Total (Fill in the Blanks Part and Descriptive Part)</b>	:	
<b>Grand Total</b>	:	
<b>Total Marks (in words)</b>	:	
<b>Signature of Examiner(s)</b>	:	
<b>Signature of Head Examiner(s)</b>	:	
<b>Signature of Scrutinizer</b>	:	
<b>Signature of Chief Scrutinizer</b>	:	
<b>Signature of Coordinating Head Examiner</b>	:	